

FISCO Spirit Levels

Combining exceptional accuracy with remarkable durability, Fisco's extensive range of spirit levels covers the requirements of all end users. From the professional range to the trade range, all Fisco levels are subject to the same rigorous quality checks to ensure that the end product meets the highest standards of accuracy, reliability and construction.



Continual testing

The research and development of Fisco professional and trade spirit levels has resulted in some of the highest quality standards in the World. Sample profiles from each range are subjected to intensive testing with laboratory bend tests using 5000N and buckle tests of up to 50,000N.

Vials undergo UV fade & temperature resistance, leak and static testing.

Optimum accuracy

A 200mm radius is the ideal balance between bubble movement and sensitivity. 500mm+ is used on good tripod mounted laser levels, which require fine mechanical adjustment - too sensitive for hand-held levels. 100mm radius can be found on some lower quality levels - the bubble hardly shifts on small adjustments.

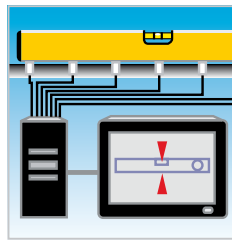
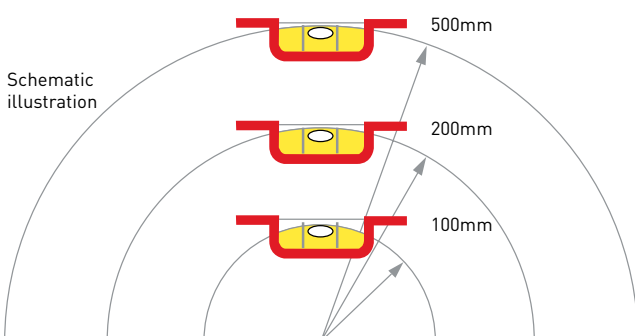

• Rigorous quality control

Throughout the entire production process, each level profile and its vials are rigorously tested electronically and mechanically to ensure that it achieves the highest standard of accuracy and build quality.

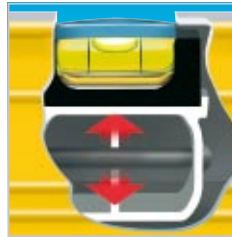

• Ultra-firm bonding of vials

Vial mounting structures are specific to each profile. Securely bonding the vial into the profile ensures that accuracy is maintained despite the rigours of on-site use and environmental conditions.



• Shock absorbing end-caps

Seriously tough - the shock tested, specially constructed end-caps effectively absorb shocks when the level is dropped on end.



• Magnification to assist reading

Horizontal vials have a magnifying lens to greatly improve readability in use. All vials can also be read inverted and with minimum optical parallax.

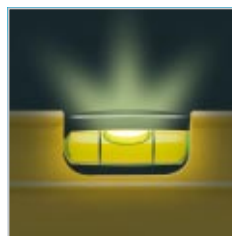

• Fluorescent vials

Most Fisco levels horizontal vials have a luminous backing plate to provide improved visibility in dark or dim conditions.



• UV, temperature and static resistant

The advanced materials used ensure the vials are fade resistant to UV and minimise the static charges that could affect accuracy.

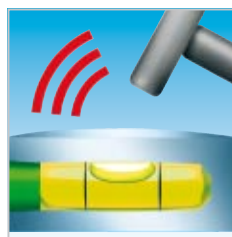

• Impact resistant vials

Fisco vials are made of super tough PMMA acrylic, which is highly impact resistant. The crystal clear vials contain a low viscosity fluid providing even bubble movement. So tough are the vials that they are guaranteed against leaks for 30 years.

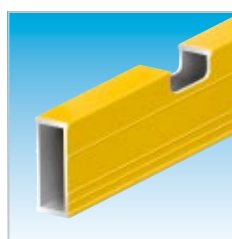

• Structural profiles designed for strength

Fisco professional levels use F25 alloy, constructed so that the top and base edges are thicker to optimise strength. The vial cut-outs are minimised in size to retain the optimum degree of structural integrity.